

DURADRIE THREADED ANCHOR

Reference: **DDTA**

Date: **02/12/2022**

Revision: 3

Page: **1 of 7**



CHARACTERISTICS

- Pilot hole in concrete needed; thread is created by the anchor during the installation process
- No special drill bit required; install using standard-sized ANSI tolerance drill bits
- Code listed under IBC/IRC in accordance with ICC-ES AC193 and ACI 355.2 for cracked and uncracked concrete.
- Qualified for static, wind and seismic loading conditions
- Removable, leaving concrete surface flat. Ideal for temporary anchoring (e.g. formwork, bracing) or applications where fixtures may need to be moved
- Suitable when reduced edge distances or spacing required
- Zinc plated coating

APPLICATIONS

- Structural fixings in cracked and uncracked concrete.
- Formwork and fixing
- Racking and shelving
- Attaching railings, handrails and ledgers
- Fixings of steel beams, channels, boilers, signals, stadium seatings, façade substructures, etc.

APPROVALS



ESR-4852

Codes compliance:
 IBC 2018, 2015, 2013, 2009
 IRC 2018, 2015, 2013, 2009
 LABC 2020
 LARC 2020
 CBC 2019
 CRC 2019
 FBC 2020, 2017
 FRC 2020, 2017

BASE MATERIALS



ALLOWABLE TENSION LOADS FOR DEEP EMBEDMENT DEPTH IN 2500 psi UNCRACKED CONCRETE with $\alpha=1.48$ [lb]

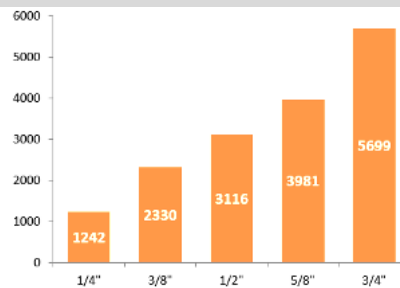

SIZES

1/4" – 3/4"

DRILL CONDITION



Dry

APPLICATION EXAMPLES



1. RANGE

ITEM	CÓDE	SIZE	PICTURE	COMPONENT	MATERIAL
1	DDTA	1/4" - 3/4"		Hexagonal screw anchor	Carbon steel, zinc plated coating $\geq 0,0002$ in

DURADRIE THREADED ANCHOR

Reference: DDTA

Date: 02/12/2022

Revision: 3

Page: 2 of 7

2. INSTALLATION DETAILS

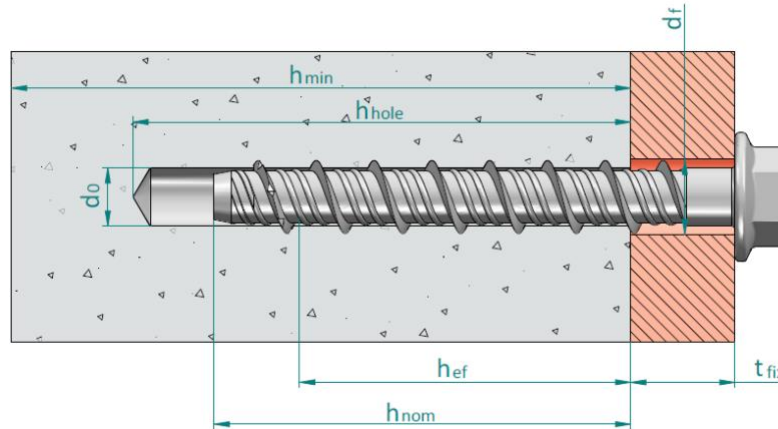

Parameter	Symbol	Units	Nominal anchor diameter									
			1/4"		3/8"		1/2"		5/8"		3/4"	
Drill bit diameter	d_0	in (mm)	1/4 (6.4)	1/4 (6.4)	3/8 (9.5)	3/8 (9.5)	1/2 (12.7)	1/2 (12.7)	5/8 (15.9)	5/8 (15.9)	3/4 (19.1)	3/4 (19.1)
Nominal embedment depth ¹	h_{nom}	in (mm)	1 5/8 (41)	2 1/2 (64)	2 1/2 (64)	3 1/4 (83)	3 (76)	4 1/4 (108)	3 1/4 (83)	5 (127)	4 (102)	6 1/4 (159)
Effective embedment depth	h_{ef}	in (mm)	1.23 (31)	1.98 (50)	1.85 (47)	2.49 (63)	2.21 (56)	3.27 (83)	2.36 (60)	3.85 (98)	2.97 (75)	4.89 (124)
Minimum hole depth	h_{hole}	in (mm)	2 (51)	2 7/8 (73)	2 3/4 (70)	3 1/2 (89)	3 3/8 (86)	4 5/8 (117)	3 5/8 (92)	5 3/8 (137)	4 3/8 (111)	6 5/8 (168)
Maximum fixture clearance Hole diameter	d_f	in (mm)	3/8 (9.5)	3/8 (9.5)	1/2 (12.7)	1/2 (12.7)	5/8 (15.9)	5/8 (15.9)	3/4 (19.1)	3/4 (19.1)	7/8 (22.2)	7/8 (22.2)
Maximum installation torque	$T_{inst,max}$	ft lb (Nm)	15 (20)	24 (33)	35 (47)	50 (68)	45 (61)	65 (88)	85 (115)	100 (136)	115 (156)	150 (203)
Maximum impact wrench torque rating	$T_{impact,max}$	ft lb (Nm)	150 (203)	150 (203)	380 (515)	380 (515)	380 (515)	380 (515)	380 (515)	380 (515)	380 (515)	380 (515)
Minimum concrete thickness	h_{min}	in (mm)	3 1/4 (83)	4 (102)	4 (102)	4 3/4 (121)	4 3/4 (121)	6 3/4 (171)	5 (127)	7 (178)	6 (152)	8 1/8 (206)
Critical edge distance	c_{ac}	in (mm)	2 1/2 (64)	3 (76)	4 (102)	5 (127)	4 1/2 (114)	5 (127)	3 3/4 (95)	7 (178)	4 1/2 (114)	8 (203)
Minimum edge distance	c_{min}	in (mm)	1 1/2 (38)	2 (51)	1 1/2 (38)	1 1/2 (38)	1 3/4 (44)	1 3/4 (44)	1 3/4 (44)	1 3/4 (44)	1 3/4 (44)	1 3/4 (44)
Minimum spacing	s_{min}	in (mm)	3 (76)	3 (76)	3 (76)	3 (76)	3 (76)	3 (76)	4 (102)	4 (102)	4 (102)	4 (102)
Minimum overall anchor length ²	l_{anch}	in (mm)	1 3/4 (44.5)	2 5/8 (66.7)	2 3/4 (70)	3 1/2 (89)	3 1/4 (82)	4 1/2 (114)	3 1/2 (89)	5 1/4 (133)	4 1/4 (108)	6 1/4 (165)
Spanner	Sw	in	7/16	7/16	9/16	9/16	3/4	3/4	15/16	15/16	1 1/8	1 1/8
Maximum fixture thickness	t_{fix}	in (mm)	L - 1.6 (L-41)	L - 2.5 (L-64)	L - 2.5 (L-64)	L-3.25 (L-83)	L-3 (L-76)	L-4.25 (L-108)	L-3.25 (L-83)	L-5 (L-127)	L-4 (L-102)	L-6.25 (L-159)

For SI: 1 inch = 25.4 mm, 1 ft-lb = 1.356 Nm.

- The embedment depth, h_{nom} , is measured from the outside surface of the concrete member to the embedded end of the anchor.
- The listed minimum overall anchor length is based on anchor sizes commercially available at the time of publication compared with the requirements to achieve the minimum nominal embedment depth and possible fixture attachment.
- Caution: holes in metal fixtures to be mounted should match the diameter specified in the table below.
- Caution: oversized holes in base material will reduce or eliminate the mechanical interlock of the threads with the base material and reduce the anchor's load capacity
- Caution: reuse of the anchor to achieve listed load values is not recommended

DURADRIVE THREADED ANCHOR

Reference: DDTA

Date: 02/12/2022

Revision: 3

Page: 3 of 7

3. PRODUCT INSTALLATION

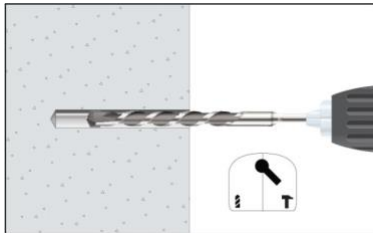

1. DRILL

Drill a hole into the base material of the correct diameter and depth using a drill bit that meets the requirements of ANSI B212.15

Caution: oversized holes in base material will reduce or eliminate the mechanical interlock of the threads with the base material and reduce the anchor's load capacity



2. BLOW AND CLEAN

Remove dust and debris from hole using a hand pump, compressed air or a vacuum to remove loose particles left from drilling.

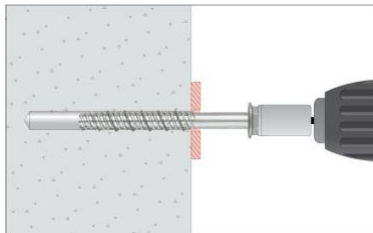

3. INSTALL

Select a powered impact wrench or a torque wrench that does not exceed the maximum torque $T_{\text{impact,max}}$ or $T_{\text{ins,max}}$ respectively. Attach appropriately sized hex socket to the wrench. Mount the threaded anchor head in the socket.

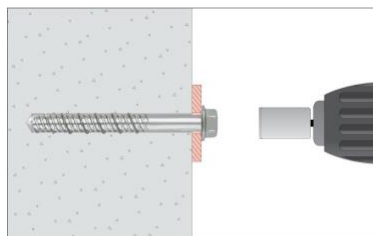



4. APPLY TORQUE

Drive the anchor with an impact driver or a torque wrench through the fixture and into the hole until the anchor head washer comes in contact with the fixture. The anchor must be snug after installation. Do not spin the hex socket off the anchor to disengage.

The threaded anchor is permitted to be loosened by a maximum of one full turn and retightened with a torque wrench or a powered impact wrench to facilitate fixture attachment or realignment

Installation accessories

Code no.	Description	qty.	Image
31417	Hand pump / Dust blower.	1	
31427	Cleaning brushes	1	
31428			
31432			
31434			

TECHNICAL DATA SHEET

DURADRIE THREADED ANCHOR

Reference: **DDTA**

Date: **02/12/2022**

Revision: **3**

Page: **4 of 7**

4. DESIGN INFORMATION

Tension design information^{1,2}

Design characteristic	Notation	Units	Nominal anchor diameter										
			1/4"		3/8"		1/2"		5/8"		3/4"		
Nominal embedment depth	h_{nom}	in (mm)	1 5/8 (41)	2 1/2 (64)	2 1/2 (64)	3 1/4 (83)	3 (76)	4 1/4 (108)	3 1/4 (83)	5 (127)	4 (102)	6 1/4 (159)	
Anchor category	1, 2 or 3	-	2		1		1		1		1		
STEEL STRENGTH IN TENSION (ACI 318-14 17.4.1 or ACI 318-11 D.5.1)													
Minimum specified ultimate strength	f_{uta}	psi (N/mm ²)	110,000 (758)		111,000 (765)		107,000 (738)		102,000 (703)		99,000 (683)		
Minimum specified yield strength	f_y	psi (N/mm ²)	88,000 (607)		88,800 (612)		85,600 (590)		81,600 (563)		79,200 (546)		
Effective tensile stress area (threaded anchor body)	$A_{se,N}$	in ² (mm ²)	0.0438 (28.3)		0.0943 (60.8)		0.1768 (114.1)		0.2703 (174.4)		0.3988 (257.3)		
Steel strength in tension ³	N_{sa}	lb (kN)	4,820 (21.4)		10,467 (46.6)		18,918 (84.1)		27,571 (122.6)		39,481 (175.6)		
Strength reduction factor for steel failure in tension ⁴	ϕ_{sa}	-	0.65										
PULLOUT STRENGTH IN TENSION (ACI 318-14 17.4.3 or ACI 318-11 D.5.3)													
Characteristic pullout strength, uncracked concrete (2,500 psi) ^{6,7}	$N_{p,uncr}$	lb (kN)	1,600 (7.12)	3,345 (14.87)	-	-	-	-	-	-	-	-	
Characteristic pullout strength, cracked concrete (2,500 psi) ^{6,7}	$N_{p,cr}$	lb (kN)	730 (3.26)	1,330 (5.91)	-	-	3,223 (14.33)	-	-	-	-	-	
Characteristic pullout strength, cracked concrete (2,500 psi), seismic ^{6,7,8}	$N_{p,eq}$	lb (kN)	730 (3.26)	1,330 (5.91)	-	-	3,223 (14.33)	-	-	-	-	-	
Normalization exponent	Uncracked concrete	n	-	0.42	0.37	-	-	0.50	-	-	-	-	
	Cracked concrete	n	-	0.39	0.50	-	-	0.35	-	-	-	-	
Strength reduction factor for pullout strength in tension ⁴	ϕ_{cb}	-	0.55			0.65							
CONCRETE BREAKOUT STRENGTH IN TENSION (ACI 318-14 17.4.2 or ACI 318-11 D.5.2)													
Effective embedment	h_{ef}	in (mm)	1.23 (31)	1.98 (50)	1.85 (47)	2.49 (63)	2.21 (56)	3.27 (83)	2.36 (60)	3.85 (98)	2.97 (75)	4.89 (124)	
Effectiveness factor for uncracked concrete ⁹	k_{uncr}	-	24	24	27	27	27	24	24	24	24	24	
Effectiveness factor for cracked concrete ⁹	k_{cr}	-	17	17	17	17	21	17	17	17	17	17	
Critical edge distance	c_{ac}	in (mm)	2 1/2 (64)	3 (76)	4 (102)	5 (127)	4 1/2 (114)	5 (127)	3 3/4 (95)	7 (178)	4 1/2 (114)	8 (203)	
Strength reduction factor for pullout strength in tension ⁴	ϕ_p	-	0.55			0.65							
Axial stiffness in service load range	Uncracked concrete	β_{uncr}	lb/in (kN/mm)	214,520 (37,570)	178,090 (31,190)	63,150 (11,059)	207,850 (36,400)	139,250 (24,386)	140,060 (24,528)	222,870 (39,031)	254,980 (44,653)	292,630 (51,247)	305,530 (53,506)
	Cracked concrete	β_{cr}	lb/in (kN/mm)	186,270 (32,620)	178,950 (31,340)	63,150 (11,059)	174,020 (30,476)	130,385 (22,834)	140,060 (24,528)	105,130 (18,411)	192,280 (33,673)	160,050 (28,029)	165,525 (28,968)
For SI: 1 inch = 25.4 mm, 1 in ² = 645 mm ² , 1 psi = 0.00689 N/mm ² ; 1 lb = 0.00445 kN, 1 lb/in = 0.175 kN/mm													
<ol style="list-style-type: none"> The data in this table is intended to be used with the design provisions of ACI 318-14 Chapter 17 or ACI 318 Appendix D, as applicable; for anchors resisting seismic load combinations the additional requirements of ACI 318-14 17.2.3 or ACI 318 D.3.3, as applicable, shall apply. Installation must comply with published instructions and details. Tabulated values for steel strength in tension are based on test results per ACI 355.2 and must be used for design. All values of ϕ were determined from the load combinations of IBC Section 1605.2, ACI 318-14 Section 5.3 or ACI 318-11 Section 9.2, as applicable. If the load combinations of ACI 318-11 Appendix C are used, then the appropriate value of ϕ must be determined in accordance with ACI 318-11 D.4.4. For reinforcement that meets ACI 318-14 Chapter 17 or ACI 318 Appendix D, as applicable, requirements for Condition A, see ACI 318-14 17.3.3 or ACI 318-11 D.4.3, as applicable, for the appropriate ϕ factor when the load combinations of IBC Section 1605.2, ACI 318-14 Section 5.3 or ACI 318-11 Section 9.2, as applicable, are used. DDTA is considered a brittle steel element in tension as defined by ACI 318-14 2.3 or ACI 318 D.1, as applicable. For concrete compressive strength greater than 2,500 psi, N_{pn} = (pullout strength value from table)ⁿ/(specified concrete compressive strength/2500)ⁿ Pullout strength does not control design of indicated anchors. Do not calculate pullout strength for indicated anchor size and embedment Reported values for characteristic pullout strength in tension for seismic applications are based on test results per ACI 355.2, Section 9.5 Select appropriate effectiveness factor for cracked concrete (k_{cr}) or uncracked concrete (k_{uncr}). Mean values shown; actual stiffness varies considerable depending on concrete strength, loading and geometry of application. Anchors are permitted to be used in sand-lightweight concrete provided that N_b, N_{eq} and N_{pn} are multiplied by a factor of 0.60. 													

DURADRIVE THREADED ANCHOR

Reference: DDTA

Date: 02/12/2022

Revision: 3

Page: 5 of 7

Shear design information^{1,2}

Design characteristic	Notation	Units	Nominal anchor diameter									
			1/4"		3/8"		1/2"		5/8"		3/4"	
Nominal embedment depth	h_{nom}	in (mm)	1 5/8 (41)	2 1/2 (64)	2 1/2 (64)	3 1/4 (83)	3 (76)	4 1/4 (108)	3 1/4 (83)	5 (127)	4 (102)	6 1/4 (159)
Anchor category	1, 2 or 3	-	2		1		1		1		1	
STEEL STRENGTH IN SHEAR (ACI 318-14 17.5.1 or ACI 318-11 D.6.1)⁵												
Minimum specified ultimate strength	f_{uta}	psi (N/mm ²)	110,000 (758)		111,000 (765)		107,000 (738)		102,000 (703)		99,000 (683)	
Minimum specified yield strength	f_y	psi (N/mm ²)	88,000 (607)		88,800 (612)		85,600 (590)		81,600 (563)		79,200 (546)	
Effective tensile stress area (threaded anchor body)	$A_{se,v}$	in ² (mm ²)	0.0438 (28.3)		0.0943 (60.8)		0.1768 (114.1)		0.2703 (174.4)		0.3988 (257.3)	
Steel strength in shear ³	V_{sa}	lb (kN)	1,555 (6.92)	2,738 (12.18)	4,817 (21.43)	4,848 (21.57)	7,268 (32.33)	9,371 (41.68)	10,300 (45.81)	12,736 (56.65)	14,238 (63.33)	14,238 (63.33)
Steel strength in shear, seismic (2500 psi) ⁵	$V_{sa,eq}$	lb (kN)	1,555 (6.92)	2,493 (11.09)	4,075 (18.13)	4,075 (18.13)	5,075 (22.57)	7,142 (31.77)	8,029 (35.72)	10,302 (45.83)	12,105 (53.85)	12,105 (53.85)
Strength reduction factor for steel failure in shear ⁶	ϕ_{sa}	-	0.60									
CONCRETE BREAKOUT STRENGTH IN SHEAR (ACI 318-14 17.5.2 or ACI 318-11 D.6.2)												
Nominal anchor diameter	d_0	in (mm)	1/4 (6.4)	1/4 (6.4)	3/8 (9.5)	3/8 (9.5)	1/2 (12.7)	1/2 (12.7)	5/8 (15.9)	5/8 (15.9)	3/4 (19.1)	3/4 (19.1)
Load bearing length of anchor	ℓ_e	in (mm)	1.23 (31)	1.98 (50)	1.85 (47)	2.49 (63)	2.21 (56)	3.27 (83)	2.36 (60)	3.85 (98)	2.97 (75)	4.89 (124)
Strength reduction factor for concrete strength in shear ⁶	ϕ_{cb}	-	0.70									
PRYOUT STRENGTH IN SHEAR (ACI 318-14 17.5.3 or ACI 318-11 D.6.3)												
Coefficient for prout strength	k_{cp}	-	1.0	1.0	1.0	1.0	1.0	2.0	1.0	2.0	2.0	2.0
Effective embedment depth	h_{ef}	in (mm)	1.23 (31)	1.98 (50)	1.85 (47)	2.49 (63)	2.21 (56)	3.27 (83)	2.36 (60)	3.85 (98)	2.97 (75)	4.89 (124)
Reduction factor for prout strength in shear ⁶	ϕ_{cp}	-	0.70									
<p>For SI: 1 inch = 25.4 mm, 1 in² = 645 mm², 1 psi = 0.00689 N/mm²; 1 lb = 0.00445 kN</p> <ol style="list-style-type: none"> The data in this table is intended to be used with the design provisions of ACI 318-14 Chapter 17 or ACI 318 Appendix D, as applicable; for anchors resisting seismic load combinations the additional requirements of ACI 318-14 17.2.3 or ACI 318 D.3.3 shall apply, as applicable. Installation must comply with published instructions and details. Reported values for steel strength in shear are based on test results per ACI 355.2, Section 9.4 and shall be used for design. DDTA is considered a brittle steel element as defined by ACI 318-14 2.3 or ACI 318-11 D.1, as applicable. Reported values for steel strength in shear for seismic applications are based on test results per ACI 355.2, Section 9.6 All values of ϕ were determined from the load combinations of IBC Section 1605.2, ACI 318-14 Section 5.3 or ACI 318 Section 9.2. If the load combinations of ACI 318-11 Appendix C are used, then the appropriate value of Φ must be determined in accordance with ACI 318-11 D.4.4. For reinforcement that meets ACI 318-14 Chapter 17 or ACI 318-11 Appendix D, as applicable, requirements for Condition A, see ACI 318-14 17.3.3 or ACI 318-11 D.4.3, for the appropriate ϕ factor when the load combinations of IBC Section 1605.2, ACI 318-14 Section 5.3 or ACI 318 Section 9.2 are used. Anchors are permitted to be used in sand-lightweight concrete provided that V_b and V_{cp} are multiplied by a factor of 0.60. 												

DURADRIVE THREADED ANCHOR

Reference: DDTA

Date: 02/12/2022

Revision: 3

Page: 6 of 7

Factored design strength (ΦN_n and ΦV_n) calculated in accordance with ACI 318-14:

- Tabular values are provided for illustration and are applicable for single anchors installed in normal weight concrete with minimum slab thickness, $h_a = h_{min}$, and with the following conditions:
 - C_{a1} is greater than or equal to the critical edge distance, C_{ac} (table values based on $C_{a1} = C_{ac}$).
 - C_{a2} is greater than or equal to 1.5 times C_{a1} .
- Calculations were performed according to ACI 318-14. The load level corresponding to the controlling failure mode is listed. (e.g., For tension: steel, concrete breakout and pullout; For shear: steel, concrete breakout and pryout). Furthermore, the capacities for concrete breakout strength in tension and pryout strength in shear are calculated using the effective embedment values, h_{ef} , for the selected anchors as noted in the design information tables. Please also reference the installation specifications for more information.
- Strength reduction factors (Φ) were based on ACI 318-14 section 17.3.3 for load combinations. Condition B is assumed. Condition B is applied where supplementary reinforcement is not supplied.
- Tabular values are permitted for static loads only, seismic loading is not considered with these tables.
- For designs that include combined tension and shear, the interaction of tension and shear loads must be calculated in accordance with ACI 318-14 section 17.6.
- Interpolation is not permitted to be used with the tabular values. For intermediate base material compressive strengths please see ACI 318-14. For other design conditions including seismic considerations please see ACI 318-14.

Tension and shear design strengths for DURADRIVE THREADED ANCHOR in cracked concrete

Nominal anchor diameter (in.)	Nominal embed. h_{nom} (in.)	Minimum concrete compressive strength									
		$f'_c = 2,500$ psi		$f'_c = 3,000$ psi		$f'_c = 4,000$ psi		$f'_c = 6,000$ psi		$f'_c = 8,000$ psi	
		ΦN_n Tension (lb.)	ΦV_n Shear (lb.)	ΦN_n Tension (lb.)	ΦV_n Shear (lb.)	ΦN_n Tension (lb.)	ΦV_n Shear (lb.)	ΦN_n Tension (lb.)	ΦV_n Shear (lb.)	ΦN_n Tension (lb.)	ΦV_n Shear (lb.)
1/4	1 5/8	403	812	417	889	441	933	478	933	505	933
	2 1/2	730	1,643	764	1,643	821	1,643	909	1,643	977	1,643
3/8	2 1/2	1,390	1,497	1,523	1,640	1,759	1,894	2,154	2,319	2,487	2,678
	3 1/4	2,171	2,338	2,378	2,561	2,746	2,909	3,363	2,909	3,883	2,909
1/2	3	2,095	2,415	2,163	2,645	2,275	3,054	2,442	3,741	2,568	4,320
	4 1/4	3,267	5,623	3,579	5,623	4,133	5,623	5,061	5,623	5,844	5,623
5/8	3 1/4	2,003	2,157	2,194	2,363	2,534	2,729	3,103	3,342	3,583	3,859
	5	4,147	7,642	4,572	7,642	5,279	7,642	6,466	7,642	7,466	7,642
3/4	4	2,828	6,091	3,098	6,672	3,577	7,704	4,381	8,543	5,059	8,543
	6 1/4	5,974	8,543	6,545	8,543	7,557	8,543	9,256	8,543	10,687	8,543

Color code: Pullout █ Concrete / pryout █ Steel █

Tension and shear design strengths for DURADRIVE THREADED ANCHOR in uncracked concrete

Nominal anchor diameter (in.)	Nominal embed. h_{nom} (in.)	Minimum concrete compressive strength									
		$f'_c = 2,500$ psi		$f'_c = 3,000$ psi		$f'_c = 4,000$ psi		$f'_c = 6,000$ psi		$f'_c = 8,000$ psi	
		ΦN_n Tension (lb.)	ΦV_n Shear (lb.)	ΦN_n Tension (lb.)	ΦV_n Shear (lb.)	ΦN_n Tension (lb.)	ΦV_n Shear (lb.)	ΦN_n Tension (lb.)	ΦV_n Shear (lb.)	ΦN_n Tension (lb.)	ΦV_n Shear (lb.)
1/4	1 5/8	881	933	915	933	973	933	1,059	933	1,125	933
	2 1/2	1,839	1,643	1,902	1,643	2,006	1,643	2,162	1,643	2,280	1,643
3/8	2 1/2	2,208	2,378	2,419	2,605	2,793	2,890	3,421	2,890	3,950	2,890
	3 1/4	3,448	2,909	3,777	2,909	4,361	2,909	5,341	2,909	6,168	2,909
1/2	3	2,883	3,105	3,158	3,401	3,647	3,927	4,466	4,361	5,157	4,361
	4 1/4	4,612	5,623	5,053	5,623	5,834	5,623	7,145	5,623	8,251	5,623
5/8	3 1/4	2,828	3,045	3,098	3,336	3,577	3,852	4,381	4,718	5,059	5,448
	5	5,892	7,642	6,455	7,642	7,453	7,642	9,128	7,642	10,540	7,642
3/4	4	3,992	8,543	4,373	8,543	5,050	8,543	6,185	8,543	7,142	8,543
	6 1/4	8,434	8,543	9,240	8,543	10,669	8,543	13,067	8,543	15,088	8,543

Color code: Pullout █ Concrete / pryout █ Steel █

DURADRIE THREADED ANCHOR

Reference: **DDTA**

Date: **02/12/2022**

Revision: **3**

Page: **7 of 7**

Converted allowable loads for TDE /TLE

ESR-4852 provides design information for load factor and characteristic resistance (LRFD), however allowable stress design (ASD) is still in use by some users. Translation of LRFD to ASD values is possible, however it is dependent on the levels of dead load and live load. Dead load is defined in the ACI 318 Building Code Requirements for Structural Concrete as "the weights of members, supported structure and permanent attachments that are likely to be present on a structure in service". Live load is defined in ACI 318-14 as "load that is not permanently applied to a structure, but is likely to occur during the service life of the structure (excluding environmental loads)". Examples of live loads are traffic on a walkway and non permanent loads associated with usage of a structure. Live load values are stipulated in the building code for various loading conditions and parts of structures.

To facilitate the translation of LRFD characteristic values to ASD values, a scenario of dead load and live load level is used to conservatively address the most common application as follows: 30% dead load; 70% live load. ACI 318-14 Equation (5.3.1b) provides a conversion factor of 1.48 which is divided into the LRFD characteristic resistances and multiplied by a ϕ factor (according to the failure type) to determine an equivalent ASD load.

It is the responsibility of the user to select the appropriate ASD values based on the example loadings shown in this document or alternative dead versus live loading that may be applicable to the specific design.

The ASD values are provided in the following tables for tension and shear for different concrete strengths. Other installation and design provisions in ESR-4852 must be followed.

Converted allowable loads for TDE /TLE in cracked concrete

Nominal anchor diameter (in.)	Nominal embed. h_{nom} (in.)	Minimum concrete compressive strength									
		$f'_c = 2,500$ psi		$f'_c = 3,000$ psi		$f'_c = 4,000$ psi		$f'_c = 6,000$ psi		$f'_c = 8,000$ psi	
		$T_{allowable ASD}$ Tension (lb)	$V_{allowable ASD}$ Shear (lb)	$T_{allowable ASD}$ Tension (lb)	$V_{allowable ASD}$ Shear (lb)	$T_{allowable ASD}$ Tension (lb)	$V_{allowable ASD}$ Shear (lb)	$T_{allowable ASD}$ Tension (lb)	$V_{allowable ASD}$ Shear (lb)	$T_{allowable ASD}$ Tension (lb)	$V_{allowable ASD}$ Shear (lb)
1/4	1 5/8	272	548	282	601	298	630	323	630	341	630
	2 1/2	494	1,110	517	1,110	555	1,110	614	1,110	660	1,110
3/8	2 1/2	939	1,012	1,029	1,108	1,188	1,280	1,455	1,567	1,680	1,810
	3 1/4	1,467	1,580	1,607	1,730	1,855	1,965	2,272	1,965	2,624	1,965
1/2	3	1,415	1,632	1,461	1,787	1,537	2,064	1,650	2,528	1,735	2,919
	4 1/4	2,207	3,779	2,418	3,779	2,792	3,779	3,420	3,779	3,949	3,779
5/8	3 1/4	1,353	1,458	1,483	1,597	1,712	1,844	2,097	2,258	2,421	2,607
	5	2,820	5,163	3,089	5,163	3,587	5,163	4,369	5,163	5,045	5,163
3/4	4	1,911	4,115	2,093	4,508	2,417	5,206	2,960	5,772	3,418	5,772
	6 1/4	4,037	5,772	4,422	5,772	5,106	5,772	6,254	5,772	7,221	5,772

- Allowable load values are calculated using a conversion factor, α , from factored design strengths.
- Tabulated allowable load values assume 30% dead load and 70% live load, with controlling load combination 1.2D + 1.6L. Calculated weighted average for the conversion factor, $\alpha = 1.2*(0.3) + 1.6*(0.7) = 1.48$.

Converted allowable loads for TDE in uncracked concrete

Nominal anchor diameter (in.)	Nominal embed. h_{nom} (in.)	Minimum concrete compressive strength									
		$f'_c = 2,500$ psi		$f'_c = 3,000$ psi		$f'_c = 4,000$ psi		$f'_c = 6,000$ psi		$f'_c = 8,000$ psi	
		$T_{allowable ASD}$ Tension (lb)	$V_{allowable ASD}$ Shear (lb)	$T_{allowable ASD}$ Tension (lb)	$V_{allowable ASD}$ Shear (lb)	$T_{allowable ASD}$ Tension (lb)	$V_{allowable ASD}$ Shear (lb)	$T_{allowable ASD}$ Tension (lb)	$V_{allowable ASD}$ Shear (lb)	$T_{allowable ASD}$ Tension (lb)	$V_{allowable ASD}$ Shear (lb)
1/4	1 5/8	595	630	619	630	657	630	715	630	760	630
	2 1/2	1,242	1,110	1,285	1,110	1,355	1,110	1,461	1,110	1,541	1,110
3/8	2 1/2	1,492	1,607	1,634	1,760	1,887	1,953	2,311	2,116	2,669	1,953
	3 1/4	2,330	1,965	2,552	1,965	2,947	1,965	3,609	1,965	4,167	1,965
1/2	3	1,948	2,098	2,134	2,298	2,464	2,653	3,018	2,947	3,485	2,947
	4 1/4	3,116	3,799	3,414	3,799	3,942	3,799	4,828	3,799	5,575	3,799
5/8	3 1/4	1,911	2,058	2,093	2,254	2,417	2,603	2,960	3,188	3,418	3,681
	5	3,981	5,165	4,361	5,165	5,036	5,165	6,168	5,165	7,122	5,165
3/4	4	2,698	5,772	2,955	5,772	3,412	5,772	4,179	5,772	4,826	5,772
	6 1/4	5,699	5,772	6,243	5,772	7,209	5,772	8,829	5,772	10,195	5,772

- Allowable load values are calculated using a conversion factor, α , from factored design strengths.
- Tabulated allowable load values assume 30% dead load and 70% live load, with controlling load combination 1.2D + 1.6L. Calculated weighted average for the conversion factor, $\alpha = 1.2*(0.3) + 1.6*(0.7) = 1.48$.



DIVISION: 03 00 00—CONCRETE
Section: 03 16 00—Concrete Anchors

DIVISION: 05 00 00—METALS
Section: 05 05 19—Post-Installed Concrete Anchors

REPORT HOLDER:

INVESTMENTS HARDWARE LIMITED

EVALUATION SUBJECT:

**DURADRIVE THREADED ANCHORS FOR USE IN
 CRACKED AND UNCRACKED CONCRETE**

1.0 EVALUATION SCOPE

Compliance with the following codes:

- 2018, 2015, 2012 and 2009 International Building Code® (IBC)
- 2018, 2015, 2012 and 2009 International Residential Code® (IRC)

For evaluation for compliance with codes adopted by the Los Angeles Department of Building and Safety (LADBS), see [ESR-4852 LABC and LARC Supplement](#).

For evaluation for compliance with codes adopted by the California Office of Statewide Health Planning and Development (OSHPD) and Division of the State Architects (DSA), see [ESR-4852 CBC and CRC Supplement](#).

Property evaluated:

Structural

2.0 USES

The Duradrive Threaded Anchors are used as anchorage to resist static, wind and seismic (Seismic Design Categories A through F) tension and shear loads in cracked and uncracked normal weight and lightweight concrete having a specified compressive strength, f'_c , of 2,500 psi to 8,500 psi (17.2 MPa to 58.6 MPa).

The Duradrive Threaded Anchors comply with Section 1901.3 of the 2018 and 2015 IBC, Section 1909 of the 2012 IBC and Section 1912 of the 2009 IBC. The Duradrive Threaded Anchors are an alternative to cast-in-place anchors described in Section 1901.3 of the 2018 and 2015 IBC, Section 1908 and 1909 of the 2012 IBC, and Section 1911 and 1912 of the 2009 IBC. The anchors may also be used where an engineered design is submitted in accordance with Section R301.1.3 of the IRC.

3.0 DESCRIPTION

3.1 DURADRIVE THREADED ANCHOR COATED:

The Duradrive Threaded Anchor Coated is comprised of a body with hex washer head. The anchor is manufactured from carbon steel and is heat treated. The anchoring system is available in a variety of lengths, with nominal diameters of 1/4 inch, 3/8 inch, 1/2 inch, 5/8 inch and 3/4 inch. It has an Atlantic epoxy coating in gray or blue colors. The anchors have been tested for corrosion resistance in accordance with ASTM G85-11 Annex 5 for handling purposes (e.g. storage). A typical Duradrive Threaded Anchor Coated is illustrated in Figure 3.

The hex head diameter is larger than the diameter of the anchor and is formed with serrations on the underside. The anchor body is formed with threads running most of the length of the anchor body. The anchor is installed in a predrilled hole with a powered impact wrench or torque wrench. The anchor threads cut into the concrete on the sides of the hole and interlock with the base material during the installation.

3.2 DURADRIVE THREADED ANCHOR ZINC:

The Duradrive Threaded Anchor Zinc is comprised of a body with hex washer head. The anchor is manufactured from carbon steel and is heat-treated. The anchoring system is available in a variety of lengths, with nominal diameters of 1/4 inch, 3/8 inch, 1/2 inch, 5/8 inch and 3/4 inch. It has a minimum of 0.0002-inch-thick (5 µm) zinc coating according to ASTM B633 type SC1, class III. A typical Duradrive Threaded Anchor Zinc is illustrated in Figure 3.

The hex head diameter is larger than the diameter of the anchor and is formed with serrations on the underside. The anchor body is formed with threads running most of the length of the anchor body. The anchor is installed in a predrilled hole with a powered impact wrench or torque wrench. The anchor threads cut into the concrete on the sides of the hole and interlock with the base material during the installation.

3.3 Concrete:

Normal weight and lightweight concrete must conform to Sections 1903 and 1905 of the IBC, as applicable.

4.0 DESIGN AND INSTALLATION

4.1 Strength Design:

4.1.1 General: Design strength of anchors complying with the 2018 and 2015 IBC, as well as Section R301.1.3 of the 2018 and 2015 IRC must be determined in accordance with ACI 318-14 Chapter 17 and this report.

Design strength of anchors complying with the 2012 IBC, as well as Section R301.1.3 of the 2012 IRC, must be in accordance with ACI 318-11 Appendix D and this report.

Design strength of anchors complying with the 2009 IBC as well as Section R301.1.3 of the 2009 IRC must be in accordance with ACI 318-08 Appendix D and this report.

Design parameters are based on the 2018 and 2015 IBC (ACI 318-14) and the 2012 IBC (ACI 318-11) unless noted otherwise in Sections 4.1.1 through 4.1.12 of this report. The strength design of anchors must comply with ACI 318-14 17.3.1 or ACI 318-11 D.4.1, as applicable, except as required in ACI 318-14 17.2.3 or ACI 318-11 D.3.3, as applicable. Strength reduction factors, ϕ , as given in ACI 318-14 17.3.3 or ACI 318-11 D.4.3, as applicable, and noted in Table 2 of this report, must be used for load combinations calculated in accordance with Section 1605.2 of the IBC and Section 5.3 of ACI 318-14 or Section 9.2 of ACI 318-11, as applicable. Strength reduction factors, ϕ , as given in ACI 318-11 D.4.4 must be used for load combinations calculated in accordance with ACI 318-11 Appendix C.

The value of f'_c used in the calculations must be limited to a maximum of 8,000 psi (55.2 MPa), in accordance with ACI 318-14 17.2.7 or ACI 318-11 D.3.7, as applicable.

4.1.2 Requirements for Static Steel Strength in Tension, N_{sa} : The nominal static steel strength in tension must be calculated in accordance with ACI 318-14 17.4.1.2 or ACI 318-11 D.5.1.2, as applicable. The values for N_{sa} are given in Table 2 of this report. Strength reduction factors, ϕ , corresponding to brittle steel elements may be used for all Duradrive Threaded Anchors.

4.1.3 Requirements for Static Concrete Breakout Strength in Tension, N_{cb} and N_{cbg} : The nominal concrete breakout strength of a single anchor or group of anchors in tension, N_{cb} and N_{cbg} , respectively, must be calculated in accordance with ACI 318-14 17.4.2 or ACI 318-11 D.5.2, as applicable, with modifications as described in this section. The basic concrete breakout strength of a single anchor in tension, N_b , must be calculated in accordance with ACI 318-14 17.4.2.2 or ACI 318-11 D.5.2.2, as applicable, using the values of h_{ef} and k_{cr} as given in Table 2 of this report. The nominal concrete breakout strength in tension, in regions where analysis indicates no cracking in accordance with ACI 318-14 17.4.2.6 or ACI 318-11 D.5.2.6, as applicable, must be calculated with the value of $\psi_{c,N} = 1.0$ and using the value of k_{uncr} as given in Table 2 of this report.

4.1.4 Requirements for Static Pullout Strength in Tension, N_p : The nominal pullout strength of a single anchor, in accordance with ACI 318-14 17.4.3.1 and 17.4.3.2 or ACI 318-11 D.5.3.1 and D.5.3.2, as applicable, in cracked and uncracked concrete, $N_{p,cr}$ and $N_{p,uncr}$, respectively, is given in Table 2 of this report. In lieu of ACI 318-14 17.4.3.6 or ACI 318-11 D.5.3.6, as applicable, $\psi_{c,P} = 1.0$ for all design cases. In accordance with ACI 318-14 17.4.3.2 or ACI 318-11 D.5.3.2, as applicable, the nominal pullout strength in cracked concrete must be adjusted by calculation according to the following equation:

$$N_{p,frc} = N_{p,cr} \left(\frac{f'_c}{2,500} \right)^n \quad (\text{lb, psi}) \quad (\text{Eq-1})$$

$$N_{p,frc} = N_{p,cr} \left(\frac{f'_c}{17.2} \right)^n \quad (\text{N, MPa})$$

In regions where analysis indicates no cracking in accordance with ACI 318-14 17.4.3.6 or ACI 318-11 D.5.3.6, as applicable, the nominal pullout strength in tension must be calculated according to the following equation:

$$N_{p,frc} = N_{p,uncr} \left(\frac{f'_c}{2,500} \right)^n \quad (\text{lb, psi}) \quad (\text{Eq-2})$$

$$N_{p,frc} = N_{p,uncr} \left(\frac{f'_c}{17.2} \right)^n \quad (\text{N, MPa})$$

n = normalization exponent given in Table 2.

Where values for $N_{p,cr}$ or $N_{p,uncr}$ are not provided in Table 2, the pullout strength in tension need not be evaluated.

4.1.5 Requirements for Static Steel Strength in Shear, V_{sa} : The nominal steel strength in shear, V_{sa} , in accordance with ACI 318-14 17.5.1.2 or ACI 318-11 D.6.1.2, as applicable, is given in Table 2 of this report and must be used in lieu of the value derived by calculation from ACI 318-14 Eq 17.5.1.2b or ACI 318-11 Eq D-29, as applicable. Strength reduction factors, ϕ , corresponding to brittle steel elements may be used for the Duradrive Threaded Anchors, as described in Table 2.

4.1.6 Requirements for Static Concrete Breakout Strength in Shear, V_{cb} or V_{cbg} : The nominal concrete breakout strength in shear of a single anchor or group of anchors, V_{cb} or V_{cbg} , respectively, must be calculated in accordance with ACI 318-14 17.5.2 or ACI 318-11 D.6.2, as applicable, with modifications as provided in this section. The basic concrete breakout strength of a single anchor in shear, V_b , must be calculated in accordance with ACI 318-14 17.5.2.2 or ACI 318-11 D.6.2.2, as applicable, using values of l_e and d_o given in Table 2 of this report.

4.1.7 Requirements for Static Concrete Pryout Strength in Shear, V_{cp} or V_{cpg} : The nominal static concrete pryout strength of a single anchor or group of anchors in shear, V_{cp} or V_{cpg} , respectively, must be calculated in accordance with ACI 318-14 17.5.3 or ACI 318-11 D.6.3, as applicable, modified by using the value of k_{cp} provided in Table 2 of this report and the value of N_{cb} or N_{cbg} as calculated in accordance with Section 4.1.3 of this report.

4.1.8 Requirements for Seismic Design:

4.1.8.1 General: For load combinations including seismic, the design must be performed in accordance with ACI 318-14 17.2.3 or ACI 318-11 D.3.3, as applicable. Modifications to ACI 318-14 17.2.3 shall be applied under Section 1905.1.8 of the 2018 and 2015 IBC. For the 2012 IBC, Section 1905.1.9 shall be omitted. Modifications to ACI 318 (-08, -05) D.3.3 shall be applied under Section 1908.1.9 of the 2009 IBC, as applicable.

4.1.8.2 Seismic Tension: The nominal steel strength and the nominal concrete breakout strength for anchors in tension must be calculated in accordance with ACI 318-14 17.4.1 and 17.4.2 or ACI 318-11 D.5.1 and D.5.2, respectively, as applicable, as described in Sections 4.1.2 and 4.1.3 of this report. In accordance with ACI 318-14 17.4.3.2 or ACI 318-11 D.5.3.2, as applicable, the appropriate value for pullout strength in tension for seismic loads, $N_{p,eq}$ may be adjusted by calculation for concrete strength in accordance with Eq-1 and Section 4.1.4 whereby the value of $N_{p,cr}$ must be substituted with $N_{p,eq}$.

4.1.8.3 Seismic Shear: The nominal concrete breakout strength and pryout strength for anchors in shear must be calculated according to ACI 318-14 17.5.2 and 17.5.3 or ACI 318-11 D.6.2 and D.6.3, respectively, as applicable, as described in Sections 4.1.6 and 4.1.7 of this report. In accordance with ACI 318-14 17.5.1.2 or ACI 318-11 D.6.1.2, as applicable, the appropriate value for nominal steel strength for seismic loads, $V_{sa,eq}$ described in Table 2 must be used in lieu of V_{sa} .

4.1.9 Requirements for Interaction of Tensile and Shear Forces: For anchors or groups of anchors that are subject to the effects of combined tensile and shear forces, the design must be performed in accordance with ACI 318-14 17.6 or ACI 318-11 D.7, as applicable.

4.1.10 Requirements for Critical Edge Distance: In applications where $c < c_{ac}$ and supplemental reinforcement to control splitting of the concrete is not present, the concrete breakout strength in tension for uncracked concrete, calculated according to ACI 318-14 17.4.2 or ACI 318-11 D.5.2, as applicable, must be further multiplied by factor $\psi_{cp,N}$ as given by the following equation:

$$\psi_{cp,N} = \frac{c}{c_{ac}} \quad (\text{Eq-3})$$

where the factor $\psi_{cp,N}$ need not be taken as less than $1.5h_{ef} / c_{ac}$. For all other cases, $\psi_{cp,N} = 1.0$. In lieu of ACI 318-14 17.7.6 or ACI 318-11 D.8.6, as applicable, values for the critical edge distance c_{ac} must be taken from Table 1 of this report.

4.1.11 Requirements for Minimum Member Thickness, Minimum Anchor Spacing and Minimum Edge Distance: In lieu of ACI 318-14 17.7.1 and 17.7.3 or ACI 318-11 D.8.1 and D.8.3, respectively, as applicable, values of s_{min} and c_{min} as given in Table 1 of this report must be used. In lieu of ACI 318-14 17.7.5 or ACI 318-11 D.8.5, as applicable, minimum member thickness h_{min} as given in Table 1 of this report must be used.

4.1.12 Lightweight Concrete: For the use of anchors in lightweight concrete, the modification factor λ_a equal to 0.8 λ is applied to all values of $\sqrt{f'_c}$ affecting N_n and V_n .

For ACI 318-14 (2018 and 2015 IBC), ACI 318-11 (2012 IBC) and ACI 318-08 (2009 IBC), λ shall be determined in accordance with the corresponding version of ACI 318.

4.2 Allowable Stress Design (ASD):

4.2.1 General: Design values for use with allowable stress design load combinations calculated in accordance with Section 1605.3 of the IBC shall be established as follows:

$$T_{allowable,ASD} = \frac{\phi N_n}{\alpha} \quad (\text{Eq-4})$$

$$V_{allowable,ASD} = \frac{\phi V_n}{\alpha} \quad (\text{Eq-5})$$

where,

$T_{allowable,ASD}$	=	Allowable tension load (lbf or kN)
$V_{allowable,ASD}$	=	Allowable shear load (lbf or kN)
ϕN_n	=	Lowest design strength of an anchor or anchor group in tension as determined in accordance with ACI 318 (-11, -08) Appendix D or ACI 318-14 Chapter 17 as applicable and 2018 and 2015 IBC Section 1905.1.8, 2009 IBC Section 1908.1.9 and Section 4.1 of this report, as applicable. For the 2012 IBC, Section 1905.1.9 shall be omitted.
ϕV_n	=	Lowest design strength of an anchor or anchor group in shear as determined in accordance with ACI 318 (-11, -08) Appendix D or ACI 318-14 Chapter 17 as applicable and 2018 and 2015 IBC Section 1905.1.8, 2009 IBC Section 1908.1.9 and Section 4.1 of this report, as applicable. For the 2012 IBC, Section 1905.1.9 shall be omitted.
α	=	Conversion factor calculated as a weighted average of the load factors for the controlling load combination. In addition, α shall include all appropriate factors to account for nonductile failure modes and required over-strength.

The requirements for member thickness, edge distance and spacing, described in this report, must apply. An example of allowable stress design values for illustrative purposes is shown in Table 3.

4.2.2 Requirements for Interaction of Tensile and Shear Forces: The interaction must be calculated and consistent with ACI 318-14 17.6 or ACI 318 (-11 and -08) D.7, as applicable, as follows:

For shear loads $V_{applied} \leq 0.2V_{allowable,ASD}$, the full allowable load in tension $T_{allowable,ASD}$ may be taken.

For tension loads $T_{applied} \leq 0.2T_{allowable,ASD}$, the full allowable load in shear $V_{allowable,ASD}$ may be taken.

For all other cases:

$$\frac{T_{applied}}{T_{allowable,ASD}} + \frac{V_{applied}}{V_{allowable,ASD}} \leq 1.2 \quad (\text{Eq-6})$$

4.3 Installation:

Installation parameters are provided in Table 1 and in Figures 1 and 2 of this report. Anchors must be installed per the manufacturer's published instructions and this report. In case of conflict, this report governs. Anchor locations must comply with this report and the plans and specifications approved by the code official. Anchors must be installed in holes drilled into concrete using carbide-tipped drill bits complying with ANSI B212.15-1994. The nominal drill diameter must be equal to the nominal diameter of the anchor. Prior to anchor installation, the hole must be cleaned in accordance with the manufacturer's published installation instructions. The minimum drilled hole depth h_{hole} is given in Table 1. The anchor must be installed into the predrilled hole using a powered impact wrench or installed with a torque wrench until the proper nominal embedment depth is obtained. The maximum impact installation wrench torque, $T_{impact,max}$, and maximum installation torque, $T_{inst,max}$ for the manual torque wrench must be in accordance with Table 1.

Duradrive Threaded Anchors are permitted to be loosened by a maximum of one full turn and retightened with a torque wrench or a powered impact wrench to facilitate fixture attachment or realignment. Complete removal and reinstallation of the anchor is not allowed.

4.4 Special Inspection:

Periodic special inspection is required, in accordance with Section 1705.1.1 and Table 1705.3 of the 2018, 2015 or 2012 IBC, or Section 1704.15 and Table 1704.4 of the 2009 IBC, as applicable. The special inspector must make periodic inspections during anchor installation to verify anchor type, anchor dimensions, concrete type, concrete compressive strength, hole dimensions, anchor spacing, edge distances, concrete thickness, anchor embedment, installation torque, maximum impact wrench torque rating and adherence to the manufacturer's published installation instructions. The special inspector must be present as often as required in accordance with the "statement of special inspection". Under the IBC, additional requirements as set forth in Sections 1705, 1706 and 1707 must be observed, where applicable.

5.0 CONDITIONS OF USE

The Duradrive Threaded Anchors described in this report comply with, or are a suitable alternative to what is specified in, those codes listed in Section 1.0 of this report, subject to the following conditions:

- 5.1** Anchor sizes, dimensions and minimum embedment depths are as set forth in the tables of this report.
- 5.2** The anchors must be installed in accordance with the manufacturer's published installation instructions and this report, in cracked and uncracked normal weight and lightweight concrete having a specified compressive strength of $f'_c = 2,500$ psi to 8,500 psi (17.2 MPa to 58.6 MPa). In case of conflict between this report and the manufacturer's instructions, this report governs.

- 5.3 The values of f'_c used for calculation purposes must not exceed 8,000 psi (55.1 MPa).
- 5.4 The concrete shall have attained its minimum design strength prior to installation of the anchors.
- 5.5 Strength design values are established in accordance with Section 4.1 of this report.
- 5.6 Allowable stress design values are established in accordance with Section 4.2 of this report.
- 5.7 Anchor spacing and edge distance as well as minimum member thickness must comply with Table 1 of this report.
- 5.8 Prior to installation, calculations and details demonstrating compliance with this report must be submitted to the code official. The calculations and details must be prepared, signed and sealed by a registered design professional where required by the statutes of the jurisdiction in which the project is to be constructed.
- 5.9 Since an ICC-ES acceptance criteria for evaluating data to determine the performance of anchors subjected to fatigue or shock load is unavailable at this time, the use of these anchors under such conditions is beyond the scope of this report.
- 5.10 Anchors may be installed in regions of concrete where cracking has occurred or where analysis indicates cracking may occur ($f_t > f_r$), subject to the conditions of this report.
- 5.11 Anchors may be used to resist short-term loading due to wind or seismic forces in locations designated as Seismic Design Categories A through F under the IBC, subject to the conditions of this report.
- 5.12 Anchors are not permitted to support fire-resistance-rated construction. Where not otherwise prohibited by the code, anchors are permitted for installation in fire-resistance-rated construction provided that at least one of the following conditions is fulfilled:
- Anchors are used to resist wind or seismic forces only.
 - Anchors that support gravity load-bearing structural elements are within a fire-resistance-rated envelope or a fire-resistance-rated membrane, are protected by approved fire-resistance-rated materials, or have been evaluated for resistance to fire exposure in accordance with recognized standards.
- Anchors are used to support nonstructural elements.
- 5.13 Use of anchors is limited to dry, interior locations.
- 5.14 Anchors have been evaluated for reliability against brittle fracture and found not to be significantly sensitive to stress-induced hydrogen embrittlement
- 5.15 Special inspection must be provided in accordance with Section 4.4 of this report.
- 5.16 Anchors are manufactured by Ningbo Londex Industrial Co., Ltd., under an approved quality control program with inspections by ICC-ES.
- ## 6.0 EVIDENCE SUBMITTED
- 6.1 Data in accordance with the ICC-ES Acceptance Criteria for Mechanical Anchors in Concrete Elements (AC193), dated October 2017 (Editorially revised April 2018), which incorporates requirements in ACI 355.2-07, for use in cracked and uncracked concrete.
- 6.2 Data in accordance with ASTM G85-11 Annex 5 for corrosion resistance.
- 6.3 Quality control documentation.
- ## 7.0 IDENTIFICATION
- 7.1 The anchors are identified by packaging labeled with the evaluation report holder's name (Investments Hardware Limited) and address, anchor name, anchor size, and evaluation report number (ESR-4852). In addition, the anchors have the size (diameter x length, in inches) and product logo stamped on the head of each screw anchor.
- 7.2 The report holder's contact information is the following:
- INVESTMENTS HARDWARE LIMITED**
250 ROWNTREE DAIRY ROAD
VAUGHAN, ONTARIO, L4L 9J7
CANADA
(416) 748-0204
www.ihlcanada.com

TABLE 1—ANCHOR INSTALLATION PARAMETERS¹

Characteristic	Symbol	Unit	Nominal Anchor Diameter									
			1/4"		3/8"		1/2"		5/8"		3/4"	
Drill Bit Diameter	d_o	in (mm)	1/4 (6.4)	1/4 (6.4)	3/8 (9.5)	3/8 (9.5)	1/2 (12.7)	1/2 (12.7)	5/8 (15.9)	5/8 (15.9)	3/4 (19.1)	3/4 (19.1)
Nominal Embedment Depth	h_{nom}	in (mm)	1 5/8 (41)	2 1/2 (64)	2 1/2 (64)	3 1/4 (83)	3 (76)	4 1/4 (108)	3 1/4 (83)	5 (127)	4 (102)	6 1/4 (159)
Effective Embedment Depth	h_{ef}	in (mm)	1.23 (31)	1.98 (50)	1.85 (47)	2.49 (63)	2.21 (56)	3.27 (83)	2.36 (60)	3.85 (98)	2.97 (75)	4.89 (124)
Minimum Hole Depth	h_{hole}	in (mm)	2 (51)	2 7/8 (73)	2 3/4 (70)	3 1/2 (89)	3 3/8 (86)	4 5/8 (117)	3 5/8 (92)	5 3/8 (137)	4 3/8 (111)	6 5/8 (168)
Fixture Hole Diameter	d_f	in (mm)	3/8 (9.5)		1/2 (12.7)		5/8 (15.9)		3/4 (19.1)		7/8 (22.2)	
Maximum Installation Torque	$T_{inst,max}$	ft.lb (Nm)	15 (20)	24 (33)	35 (47)	50 (68)	45 (61)	65 (88)	85 (115)	100 (136)	115 (156)	150 (203)
Maximum impact wrench torque rating	$T_{impact,max}$	ft lb (Nm)	150 (203)	150 (203)	380 (515)	380 (515)	380 (515)	380 (515)	380 (515)	380 (515)	380 (515)	380 (515)
Minimum Concrete Thickness	h_{min}	in (mm)	3 1/4 (83)	4 (102)	4 (102)	4 3/4 (121)	4 3/4 (121)	6 3/4 (171)	5 (127)	7 (178)	6 (152)	8 1/8 (206)
Critical Edge Distance	c_{ac}	in (mm)	2 1/2 (64)	3 (76)	4 (102)	5 (127)	4 1/2 (114)	5 (127)	3 3/4 (95)	7 (178)	4 1/2 (114)	8 (203)
Minimum Edge Distance (c_{min})	c_{min}	in (mm)	1 1/2 (38)	2 (51)	1 1/2 (38)	1 1/2 (38)	1 3/4 (44)	1 3/4 (44)	1 3/4 (44)	1 3/4 (44)	1 3/4 (44)	1 3/4 (44)
Minimum Spacing (s_{min})	s_{min}	in (mm)	3 (76)	3 (76)	3 (76)	3 (76)	3 (76)	3 (76)	4 (102)	4 (102)	4 (102)	4 (102)
Minimum Overall Anchor Length	l_{anch}	in (mm)	1 3/4 (44)	2 5/8 (67)	2 3/4 (70)	3 1/2 (89)	3 1/4 (82)	4 1/2 (114)	3 1/2 (89)	5 1/4 (133)	4 1/4 (108)	6 1/2 (165)
Torque Wrench Socket Size	-	in	7/16		9/16		3/4		15/16		1 1/8	
Maximum Fixture Thickness ²	t_{fix}	in (mm)	L - 1 5/8 (L-41)	L - 2 1/2 (L-64)	L - 2 1/2 (L-64)	L - 3 1/4 (L-83)	L-3 (L-76)	L-4 1/4 (L-108)	L-3 1/4 (L-83)	L-5 (L-127)	L-4 (L-102)	L-6 1/4 (L-159)

1. The tabulated data is to be used in conjunction with the design criteria given in ACI 318-14 Chapter 17 or ACI 318-11 Appendix D, as applicable.
2. L = total anchor length

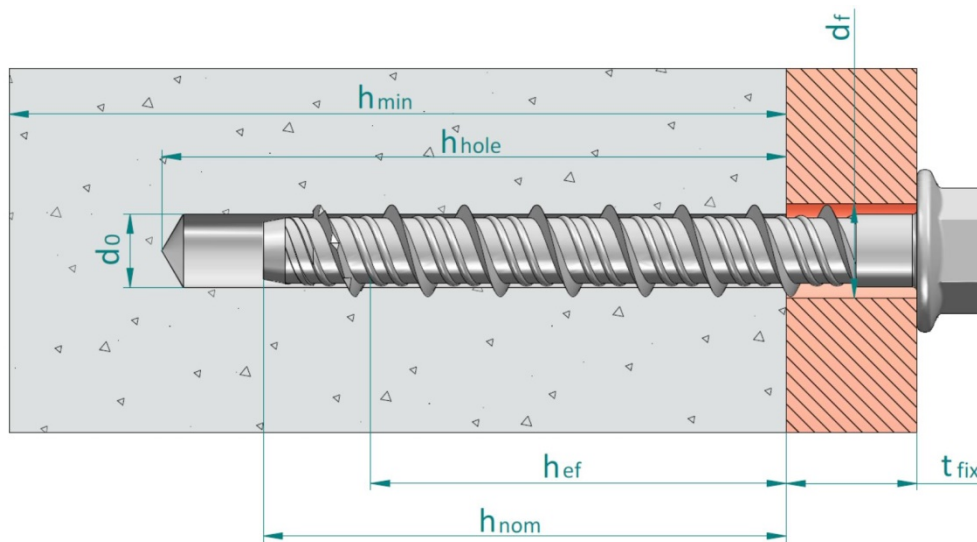
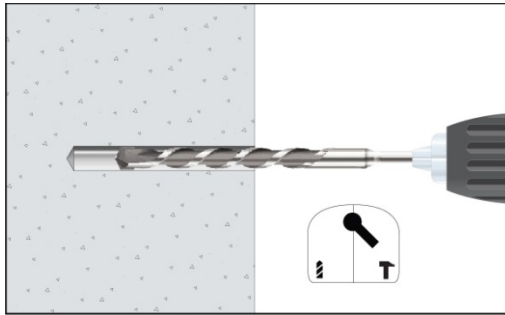

FIGURE 1—ANCHOR DIMENSIONS

TABLE 2—ANCHOR DESIGN INFORMATION^{1,2}

Characteristic	Symbol	Unit	Nominal Anchor Diameter										
			1/4"		3/8"		1/2"		5/8"		3/4"		
Nominal Embedment Depth	h_{nom}	in (mm)	1 5/8 (41)	2 1/2 (64)	2 1/2 (64)	3 1/4 (83)	3 (76)	4 1/4 (108)	3 1/4 (83)	5 (127)	4 (102)	6 1/4 (159)	
Anchor Category	1, 2 or 3	-	2				1						
Steel Strength in Tension and Shear													
Minimum specified ultimate strength	f_{uta}	psi (N/mm ²)	110,000 (758)		111,000 (765)		107,000 (738)		102,000 (703)		99,000 (683)		
Minimum specified yield strength	f_y	psi (N/mm ²)	88,000 (607)		88,800 (612)		85,600 (590)		81,600 (563)		79,200 (546)		
Effective stress area (screw anchor body)	A_{se}	in ² (mm ²)	0.0438 (28.3)		0.0943 (60.8)		0.1768 (114.1)		0.2703 (174.4)		0.3988 (257.3)		
Steel Strength in Tension	N_{sa}	lb (kN)	4,820 (21.4)		10,465 (46.6)		18,920 (84.1)		27,570 (122.6)		39,480 (175.6)		
Strength Reduction Factor for Steel Failure in Tension	ϕ_{sa}	-	0.65										
Steel Strength in Shear	V_{sa}	lb (kN)	1,555 (6.9)	2,740 (12.2)	4,815 (21.4)	4,850 (21.6)	7,270 (32.3)	9,370 (41.7)	10,300 (45.8)	12,735 (56.7)	14,240 (63.3)	14,240 (63.3)	
Steel Strength in Shear, Seismic	$V_{sa,eq}$	lb (kN)	1,555 (6.9)	2,495 (11.1)	4,075 (18.1)	4,075 (18.1)	5,075 (22.6)	7,140 (31.8)	8,030 (35.7)	10,300 (45.8)	12,105 (53.9)	12,105 (53.9)	
Strength Reduction Factor for Steel Failure in Shear	ϕ_{sa}	-	0.60										
Pullout Strength in Tension³													
Pullout Strength in Uncracked Concrete	$N_{p,uncr}$	lb (kN)	1,600 (7.1)	3,345 (14.9)	-	-	-	-	-	-	-	-	
Pullout Strength in Cracked Concrete	$N_{p,cr}$	lb (kN)	730 (3.3)	1,330 (5.9)	-	-	3,225 (14.3)	-	-	-	-	-	
Pullout Strength in Cracked Concrete, Seismic	$N_{p,eq}$	lb (kN)	730 (3.3)	1,330 (5.9)	-	-	3,225 (14.3)	-	-	-	-	-	
Normalization Exponent, Uncracked Concrete	n	-	0.42	0.37	-	-	0.50	-	-	-	-	-	
Normalization Exponent, Cracked Concrete	n	-	0.39	0.50	-	-	0.35	-	-	-	-	-	
Strength Reduction Factor for Pullout Strength in Tension	ϕ_p	-	0.55				0.65						
Concrete Breakout Strength in Tension													
Effective embedment	h_{ef}	in (mm)	1.23 (31)	1.98 (50)	1.85 (47)	2.49 (63)	2.21 (56)	3.27 (83)	2.36 (60)	3.85 (98)	2.97 (75)	4.89 (124)	
Effectiveness Factor for Uncracked Concrete	k_{uncr}	-	24			27			24				
Effectiveness Factor for Cracked Concrete	k_{cr}	-	17				21		17				
Strength Reduction Factor for Concrete Breakout Strength in Tension	ϕ_{cb}	-	0.55				0.65						
Axial stiffness in service load range in uncracked concrete	β_{uncr}	lb/inch (N/mm)	214,520 (37,570)	178,090 (31,190)	63,150 (11,059)	207,850 (36,400)	139,250 (24,386)	140,060 (24,528)	222,870 (39,031)	254,980 (44,653)	292,630 (51,247)	305,530 (53,506)	
Axial stiffness in service load range in cracked concrete	β_{cr}	lb/inch (N/mm)	186,270 (32,620)	178,950 (31,340)	63,150 (11,059)	174,020 (30,476)	130,385 (22,834)	140,060 (24,528)	105,130 (18,411)	192,280 (33,673)	160,050 (28,029)	165,525 (28,968)	
Concrete Breakout Strength in Shear													
Nominal Diameter	d_o^2	in (mm)	1/4 (6.4)	1/4 (6.4)	3/8 (9.5)	3/8 (9.5)	1/2 (12.7)	1/2 (12.7)	5/8 (15.9)	5/8 (15.9)	3/4 (19.1)	3/4 (19.1)	
Load Bearing Length of Anchor	l_e	in (mm)	1.23 (31)	1.98 (50)	1.85 (47)	2.49 (63)	2.21 (56)	3.27 (83)	2.36 (60)	3.85 (98)	2.97 (75)	4.89 (124)	
Reduction Factor for Concrete Breakout Strength in Shear	ϕ_{cb}	-	0.70										
Concrete Pryout Strength in Shear													
Coefficient for Pryout Strength	k_{cp}	-	1.0				2.0		1.0		2.0		
Reduction Factor for Pryout Strength in Shear	ϕ_{cp}	-	0.70										

1. The tabulated data is to be used in conjunction with the design criteria given in ACI 318-14 Chapter 17 or ACI 318-11 Appendix D, as applicable.
 2. All values of ϕ were determined from the load combinations of IBC Section 1605.2, ACI 318-14 Section 5.3 or ACI 318-11 Section 9.2, as applicable. If the load combinations of ACI 318-11 Appendix C are used, then the appropriate value of ϕ must be determined in accordance with ACI 318-11 D.4.4. For reinforcement that meets ACI 318-14 Chapter 17 or ACI 318 Appendix D, as applicable, requirements for Condition A, see ACI 318-14 17.3.3 or ACI 318-11 D.4.3, as applicable, for the appropriate ϕ factor when the load combinations of IBC Section 1605.2, ACI 318-14 Section 5.3 or ACI 318-11 Section 9.2, as applicable, are used.
 3. Where no value is reported for pullout strength, this resistance does not need to be considered.



1. DRILL

Drill a hole into the base material of the correct diameter and depth using a drill bit that meets the requirements of ANSI B212.15

Caution: oversized holes in base material will reduce or eliminate the mechanical interlock of the threads with the base material and reduce the anchor's load capacity

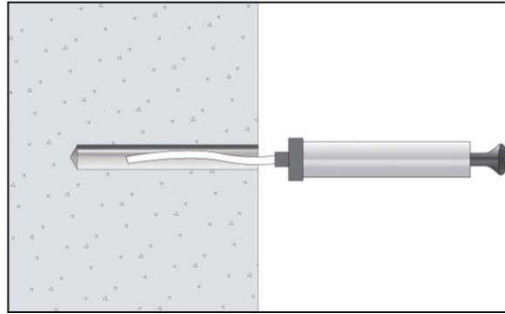

2. BLOW AND CLEAN

Remove dust and debris from hole using a hand pump, compressed air or a vacuum to remove loose particles left from drilling.

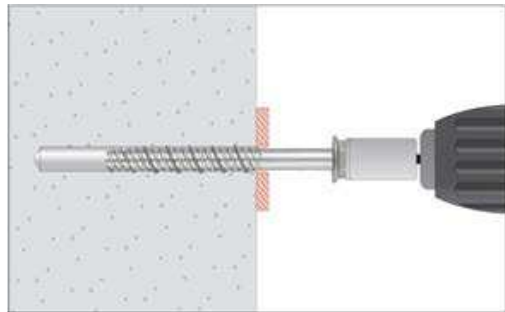

3. INSTALL

Select a powered impact wrench or a torque wrench that does not exceed the maximum torque $T_{\text{impact,max}}$ or $T_{\text{inst,max}}$ respectively. Attach an appropriate sized hex socket to the wrench. Mount the screw anchor head in the socket.

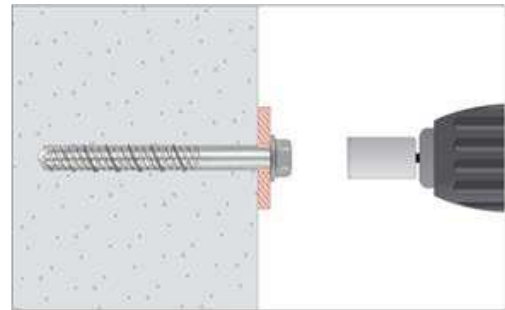

4. APPLY TORQUE

Drive the anchor with an impact driver or a torque wrench through the fixture and into the hole until the anchor head washer comes in contact with the fixture. The anchor must be snug after installation. Do not spin the hex socket off the anchor to disengage.

The screw anchors are permitted to be loosened by a maximum of one full turn and retightened with a torque wrench or a powered impact wrench to facilitate fixture attachment or realignment

FIGURE 2—MANUFACTURER'S PUBLISHED INSTALLATION INSTRUCTIONS

TABLE 3—EXAMPLE ALLOWABLE STRESS DESIGN VALUES FOR ILLUSTRATIVE PURPOSES^{1,2,3,4,5,6,7,8,9,10}

Nominal Anchor Diameter d_o (inch)	Nominal Embedment Depth h_{nom} (inch)	Allowable Tension Load $T_{allowable,ASD}$ (lb)
1/4	1 5/8	595
1/4	2 1/2	1,242
3/8	2 1/2	1,492
3/8	3 1/4	2,330
1/2	3	1,948
1/2	4 1/4	3,116
5/8	3 1/4	1,911
5/8	5	3,981
3/4	4	2,698
3/4	6 1/4	5,699

1. Single anchor.
2. Static tension loading only.
3. Concrete determined to remain uncracked for the life of the anchorage.
4. Load combinations taken from ACI 318-14 Section 5.3 or ACI 318-11 Section 9.2, as applicable with no seismic loading.
5. 30% Dead Load (D) and 70% Live Load (L), controlling load combination 1.2D + 1.6L.
6. Calculation of the weighted average for $\alpha = 1.2 \times 0.3 + 1.6 \times 0.7 = 1.48$
7. Normal weight concrete, $f'_c = 2,500$ psi.
8. $c_{a1} = c_{a2} \geq c_{ac}$
9. Concrete thickness $h \geq h_{min}$.
10. Values are for Condition B (supplementary reinforcement in accordance with ACI 318-14 7.3.3 or ACI 318-11 D.4.3 is not provided).

Illustrative procedure of Allowable Stress Design calculation. Method ACI 318-14, Chapter 17

Per the figure below and the following information:

- 2 anchors Duradrive Threaded Anchor Coated 1/2"x 3-1/4" anchor length
- Concrete: strength 4,000 psi, cracked, 5 inches thick
- $h_{ef} = 2.21$ in
- Anchor Layout: as per sketch
- Static or quasi-static loads

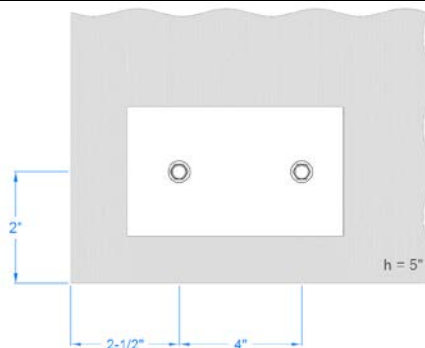

Step	ACI 318-14 Section Reference	ESR Section Reference	CALCULATIONS
1	17.7	Section 4.1.11 Table 1	Verify spacing / edge distance / member thickness $s = 4 \text{ in} > 3 \text{ in} \rightarrow \text{verified}$ $c_{a1} = 2-1/2 \text{ in} > 1-3/4 \text{ in} \rightarrow \text{verified}$ $c_{a2} = 2 \text{ in} > 1-3/4 \text{ in} \rightarrow \text{verified}$ $h = 5 \text{ in} > 4-3/4 \text{ in} \rightarrow \text{verified}$
2	17.4.1.2	Section 4.1.1.2 Table 2	Calculate steel capacity on a single fastener loaded in tension $\phi N_{sa} = (0.65) (18,920) = 12,298 \text{ lbf}$ Group of fasteners $\phi N_s = n \phi N_{sa} = (2) (12,298) = \mathbf{24,596 \text{ lbf}}$

Step	ACI 318-14 Section Reference	ESR Section Reference	CALCULATIONS (CONTINUED)
3	17.4.2.1	4.1.3	Calculation concrete strength capacity on the group of fasteners loaded in tension $\phi N_{cbg} = \phi \frac{A_{Nc}}{A_{Nco}} \psi_{ec,N} \psi_{ed,N} \psi_{c,N} \psi_{cp,N} N_b$
3.1	17.4.2.1	Table 3	$A_{Nc} = (C_{a1} + 1.5 h_{ef}) (C_{a2} + s + 1.5 h_{ef}) = (2 + 3.32) (2.5 + 4 + 3.32) = 52.24$ $A_{Nco} = 9 (h_{ef})^2 = 9 (2.21)^2 = 43.96$
3.2	17.4.2.4		No load eccentricity $\rightarrow e_v = 0 \rightarrow \psi_{ec,N} = 1.00$
3.3	17.4.2.5	Table 2	$C_{a,min} < 1.5 h_{ef} \rightarrow \psi_{ed,N} = 0.7 + 0.3 \frac{c_{a,min}}{1.5 h_{ef}} = 0.7 + 0.3 \frac{2}{3.32} = 0.88$
3.4	17.4.2.6		Cracked concrete $\rightarrow \psi_{c,N} = 1.00$
3.5	17.4.2.7		Cracked concrete $\rightarrow \psi_{cp,N} = 1.00$
3.6	17.4.2.2	4.1.3	$N_b = k_c \lambda_a \sqrt{f'_c} h_{ef}^{1.5} = (21) (1.0) \sqrt{4000} (2.21)^{1.5} = 4,363 \text{ lbf}$
	17.4.2.1	4.1.3	thus $\phi N_{cbg} = (0.65) \frac{52.24}{43.96} (1.0)(0.88)(1.0)(4,363) = 2,965 \text{ lbf}$
4	17.4.3.1	Section 4.1.4 Table 2	Calculate pull out strength on single fastener loaded in tension $\phi N_{p,f} = \phi \psi_{c,p} N_{p,2500} \left(\frac{f'_c}{2,500} \right)^n = (0.65)(1.00) (3,225) \left(\frac{4,000}{2,500} \right)^{0.35} = 2,470 \text{ lbf}$ Group of fasteners $\phi N_p = n \phi N_p = (2) (2,470) = 4,940 \text{ lbf}$
5	17.3.1.1	-	Governing tension strength: Minimum value of steel, concrete breakout, pull out: $\phi N_n = \min [\phi N_s; \phi N_c; \phi N_p] = 2,965 \text{ lbf}$
6	5.3	Section 4.2.1	Calculation of conversion factor, α , for allowable stress design $\alpha = (1.2) D + (1.6) L = (1.2) (0.30) + (1.6) (0.6) = 1.48$
7	-	Section 4.2.1	Calculation of allowable stress design in tension $T_{allowable,ASD} = \frac{\phi N_n}{\alpha} = \frac{2,965}{1.48} = 2,003 \text{ lbf}$



FIGURE 3—DURADRIE THREADED ANCHOR

DIVISION: 03 00 00—CONCRETE
Section: 03 16 00—Concrete Anchors

DIVISION: 05 00 00—METALS
Section: 05 05 19—Post-Installed Concrete Anchors

REPORT HOLDER:**INVESTMENTS HARDWARE LIMITED****EVALUATION SUBJECT:****DURADRIVE THREADED ANCHORS FOR USE IN CRACKED AND UNCRACKED CONCRETE****1.0 REPORT PURPOSE AND SCOPE****Purpose:**

The purpose of this evaluation report supplement is to indicate that the Duradrive Threaded Anchors for use in cracked and uncracked concrete, described in ICC-ES evaluation report [ESR-4852](#), have also been evaluated for compliance with the codes noted below as adopted by the Los Angeles Department of Building and Safety (LADBS).

Applicable code editions:

- 2020 *City of Los Angeles Building Code* (LABC)
- 2020 *City of Los Angeles Residential Code* (LARC)

2.0 CONCLUSIONS

The Duradrive Threaded Anchors for use in cracked and uncracked concrete, described in Sections 2.0 through 7.0 of the evaluation report [ESR-4852](#), comply with the LABC Chapter 19, and the LARC, and are subject to the conditions of use described in this supplement.

3.0 CONDITIONS OF USE

The Duradrive Threaded Anchors for use in cracked and uncracked concrete described in this evaluation report supplement must comply with all of the following conditions:

- All applicable sections in the evaluation report [ESR-4852](#).
- The design, installation, conditions of use and identification of the anchors are in accordance with the 2018 *International Building Code*® (IBC) provisions noted in the evaluation report [ESR-4852](#).
- The design, installation and inspection are in accordance with additional requirements of LABC Chapters 16 and 17, as applicable.
- Under the LARC, an engineered design in accordance with LARC Section R301.1.3 must be submitted.
- The allowable strength and design strength values listed in the evaluation report and tables are for the connection of the anchors to the concrete. The connection between the anchors and the connected members shall be checked for capacity (which may govern).
- For use in wall anchorage assemblies to flexible diaphragm applications, anchors shall be designed per the requirements of City of Los Angeles Information Bulletin P/BC 2020-71.

This supplement expires concurrently with the evaluation report, issued June 2021.

DIVISION: 03 00 00—CONCRETE
Section: 03 16 00—Concrete Anchors

DIVISION: 05 00 00—METALS
Section: 05 05 19—Post-Installed Concrete Anchors

REPORT HOLDER:

INVESTMENTS HARDWARE LIMITED

EVALUATION SUBJECT:

DURADRIVE THREADED ANCHORS FOR USE IN CRACKED AND UNCRACKED CONCRETE

1.0 REPORT PURPOSE AND SCOPE

Purpose:

The purpose of this evaluation report supplement is to indicate that the Duradrive Threaded Anchors for use in cracked and uncracked concrete, described in ICC-ES evaluation report ESR-4852, have also been evaluated for compliance with the codes noted below.

Applicable code editions:

- 2019 *California Building Code* (CBC)

For evaluation of applicable chapters adopted by the California Office of Statewide Health Planning and Development (OSHPD) and Division of the State Architect (DSA), see Sections 2.1 and 2.2 below.

- 2019 *California Residential Code* (CRC)

2.0 CONCLUSIONS

The Duradrive Threaded Anchors for use in cracked and uncracked concrete, described in Sections 2.0 through 7.0 of the evaluation report ESR-4852, comply with CBC Chapter 19 and CRC Section R301.1.3, provided the design and installation are in accordance with the 2018 *International Building Code*® (IBC), as applicable, provisions noted in the evaluation report, and the additional inspection requirements of the CBC Sections 16 and 17.

2.1 OSHPD:

The Duradrive Threaded Anchors for use in cracked and uncracked concrete, described in Sections 2.0 through 7.0 of the evaluation report ESR-4852, comply with CBC amended Sections in Chapters 16, 17 and 19, and Chapters 16A, 17A and 19A, provided the design and installation are in accordance with the 2018 *International Building Code*® (IBC), as applicable, provisions noted in the evaluation report, and the additional requirements in Sections 2.1.1 to 2.1.3 of this supplement:

2.1.1 Verification Test Requirements: The installation verification test loads, frequency, and acceptance criteria shall be in accordance with Section 1901.3.4 [OSHPD 1R, 2 and 5] and 1910A.5 [OSHPD 1 & 4] of the CBC, as applicable.

2.1.2 Special Inspection Requirements: Periodic special inspection is required, in accordance with Section 1705.1.1 and Table 1705.3 [OSHPD 1R, 2 and 5], or Section 1705A.1.1, and Table 1705A.3 [OSHPD 1 & 4] of the CBC, as applicable. In addition, special inspection is required for special seismic certification for designated seismic system in accordance with amended Section 1705.13.3.1 [OSHPD 1R, 2 and 5] and Section 1705A.12.4 [OSHPD 1 & 4] of the CBC, as applicable.

2.1.3 Conditions of Use:

1. Where moment resistance is assumed at the base of the superstructure elements, deformation of the superstructure to foundation connection shall be considered in accordance with Section 1617A.1.16 [OSHPD 1 & 4] of the CBC.
2. The screw anchors may be loosened and retightened in accordance with Section 4.3 of the evaluation report to perform verification test requirements specified in Section 2.1.1 of this supplement. Re-use of screw anchors or screw anchor holes shall not be permitted.

2.2 DSA:

The Duradrive Threaded Anchors for use in cracked and uncracked concrete, described in Sections 2.0 through 7.0 of the evaluation report ESR-4852, comply with CBC amended Sections in Chapters 16 and 19, and Chapters 16A, 17A and 19A, provided the design and installation are in accordance with the 2018 *International Building Code*[®] (IBC), as applicable, provisions noted in the evaluation report, and the additional requirements in Sections 2.2.1 to 2.2.3 of this supplement:

2.2.1 Verification Test Requirements: The installation verification test loads, frequency, and acceptance criteria shall be in accordance with Sections 1909.2.7 [DSA-SS/CC] and 1910A.5 [DSA-SS] of the CBC, as applicable.

2.2.2 Special Inspection Requirements: Periodic special inspection is required, in accordance with Section 1705A.1.1, and Table 1705A.3 [DSA-SS, DSA-SS/CC] of the CBC. In addition, special inspection is required for special seismic certification for designated seismic system in accordance Section 1705A.12.4 [DSA-SS, DSA-SS/CC] of the CBC, as applicable.

2.2.3 Conditions of Use:

1. Where moment resistance is assumed at the base of the superstructure elements, deformation of the superstructure to foundation connection shall be considered in accordance with Section 1617.11.14 [DSA-SS/CC] or Section 1617A.1.16 [DSA-SS] of the CBC.
2. The screw anchors may be loosened and retightened in accordance with Section 4.3 of the evaluation report to perform verification test requirements specified in Section 2.1.1 of this supplement. Re-use of screw anchors or screw anchor holes shall not be permitted.

This supplement expires concurrently with the evaluation report, issued June 2021.

DIVISION: 03 00 00—CONCRETE
Section: 03 16 00—Concrete Anchors

DIVISION: 05 00 00—METALS
Section: 05 05 19—Post-Installed Concrete Anchors

REPORT HOLDER:**INVESTMENTS HARDWARE LIMITED****EVALUATION SUBJECT:****DURADRIVE THREADED ANCHORS FOR USE IN CRACKED AND UNCRACKED CONCRETE****1.0 REPORT PURPOSE AND SCOPE****Purpose:**

The purpose of this evaluation report supplement is to indicate that the Duradrive Threaded Anchors, recognized in ICC-ES evaluation report ESR-4852, have also been evaluated for compliance with the codes noted below.

Applicable code editions:

- 2020 and 2017 *Florida Building Code—Building*
- 2020 and 2017 *Florida Building Code—Residential*

2.0 CONCLUSIONS

The Duradrive Threaded Anchors, described in Sections 2.0 through 7.0 of ICC-ES evaluation report ESR-4852, comply with the *Florida Building Code—Building* and the *Florida Building Code—Residential*, provided the design requirements are determined in accordance with the *Florida Building Code—Building* or the *Florida Building Code—Residential*, as applicable. The installation requirements noted in ICC-ES evaluation report ESR-4852 for the *International Building Code*® meet the requirements of the *Florida Building Code—Building* or the *Florida Building Code—Residential*, as applicable, with the following conditions:

Use of the Duradrive Threaded Anchors in dry, interior locations has also been found to be in compliance with the High-Velocity Hurricane Zone provisions of the *Florida Building Code—Building* and *Florida Building Code—Residential*.

For products falling under Florida Rule 61G20-3, verification that the report holder's quality assurance program is audited by a quality assurance entity approved by the Florida Building Commission for the type of inspections being conducted is the responsibility of an approved validation entity (or the code official when the report holder does not possess an approval by the Commission).

This supplement expires concurrently with the evaluation report, issued June 2021.